

MA15

Presentation:

The GROOVE series stage monitors are not just powerful, accurate, compact but beautifully designed. The series has been engineered to deliver a complete sound reinforcement solution to fulfil the highest demands of audio professionals for both permanent installation and rental production markets.

The GROOVE MA15 stage monitor incorporates a 15" (2.5" VC) LF loudspeaker that combines excellent linearity with good sensitivity and power handling characteristics together with a 1" (1.73in) compression driver coupled to a CD rotatable (90°x60° and 60°x90°) horn and an internal passive crossover resulting in a surprising sonic performance inside a compact package.

As self-powered system, the MA15 incorporates a 2-channel Class D amplifier and a DSP for real time operation according to different environments and music styles. With 4 user-defined presets than can be selected on the rear panel, the class D amplifier is prepared for 85-264Vac global mains voltage (SMPS with PFC) and features various electronic protections to guarantee the use of the speaker system in perfect sound and safe operation.

To make it flexible, there are M8 and M10 inserts for wall and truss mounting

As a high performance stage monitor, the GROOVE series is suited to sound reinforcement applications such as front of house, floor monitor, sidefill monitoring small and medium sized stages as well as distributed systems.

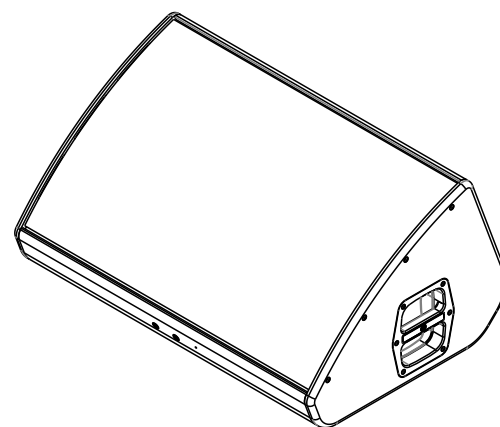

Features:

- Multipurpose 2-way stage monitor
- Bass reflex wedged enclosure
- 15" (2.5in VC) MF + 1" (1.73in VC) HF EU transducers
- User-rotatable CD horn 90°x60° for ideal dispersion
- 2-channel Class D amplifier with integrated DSP
- Universal 85-264Vac mains, SMPS with PFC
- Prepared for wall and truss mounting
- Elegant looking professional enclosure
- Rugged and durable 15mm birch plywood, polyurea coating

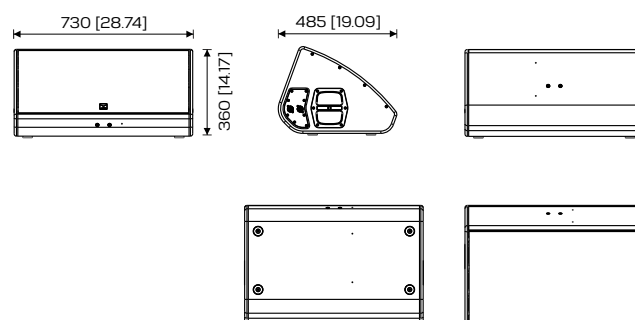

Dimensions in mm [in]

Technical specifications:

Acoustical

Type	2-way active stage monitor
Enclosure design	Wedged cabinet - bass reflex
Power rating (RMS/Peak)	410W / 1100W
Frequency range	50 - 19kHz (10dB)
Nominal impedance	N/A
Transducer type	15" MF (2.5in VC) EU transducer 1" HF driver (1.73in VC) EU transducer
Dispersion	CD horn, 90°x60° and 60°x90° user-rotatable
Crossover frequency	DSP controlled with selectable presets
SPL (1W/1kHz)	129dB @ 1m

Mechanical

Enclosure	15mm birch plywood, rugged polyurea coating
Grille	Custom perforated metal grilles w/ acoustic foam
Color	Black or white textured
Hardware	4 rubber feet Side handles, 4x M8 inserts + 2x M10 inserts Prepared to fit a "U" bracket
Dimensions	730x485x360mm 28.74x19.09x14.17in
Weight	28Kg 61.73lb

Amplifier Module

Type	2-channel Class D
Output Power	800W + 400W (continuous)
Internal Processing	Fully programmable DSP 48KHz sampling frequency 24 bit AD/DA converter
Audio input/output	XLR/Jack combo connector XLR/M 3p
Indicators	Power, signal/preset, status, clip
Controls	Master level control, 4 selectable presets
AC Mains	SMPS with PFC, 85-264Vac universal mains
AC Mains connector	Neutrik® powerCON, Power-in/Power-out
Protections	Over current, short circuit, thermal, DC and HF

