

# M15

## Presentation:

The GROOVE series stage monitors are not just powerful, accurate, compact but beautifully designed. The series has been engineered to deliver a complete sound reinforcement solution to fulfil the highest demands of audio professionals for both permanent installation and rental production markets.

The GROOVE M15 stage monitor incorporates a 12" (2.5" VC) LF loudspeaker that combines excellent linearity with good sensitivity and power handling characteristics together with a 1" (1.73in) compression driver coupled to a CD rotatable (90°x60° and 60°x90°) horn and an internal passive crossover network resulting in a surprising sonic performance inside a compact package.

To make it flexible, there are M8 and M10 inserts for wall and truss mounting.

As a high performance stage monitor, the GROOVE series is suited to sound reinforcement applications such as front of house, floor monitor, sidefill monitoring small and medium sized stages as well as distributed systems.

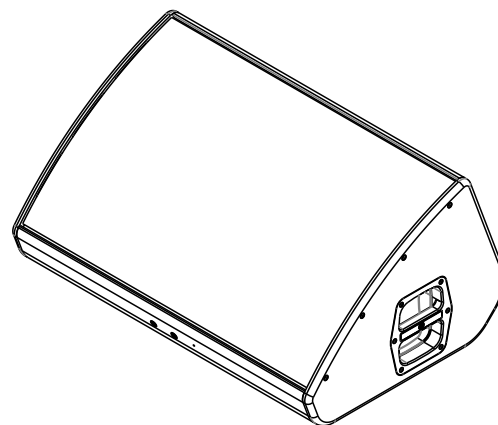

## Features:

- Multipurpose 2-way stage monitor
- Bass reflex wedged enclosure
- 15" (2.5in VC) MF + 1" (1.73in VC) HF EU transducers
- User-rotatable CD horn 90°x60° for ideal dispersion
- 2x NL4 parallel-connected
- Prepared for wall and truss mounting
- Elegant looking professional enclosure
- Rugged and durable 15mm birch plywood, polyurea coating

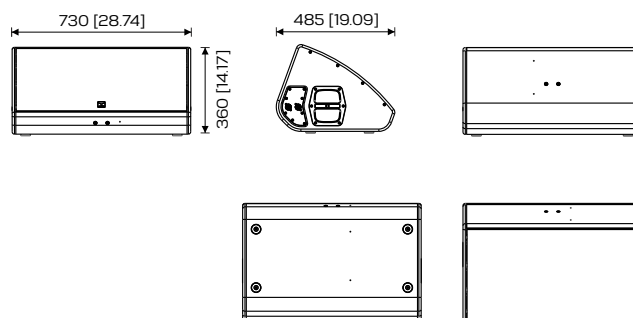

Dimensions in mm [in]

## Technical specifications:

### Acoustical

Type	2-way passive stage monitor
Enclosure design	Wedged cabinet - bass reflex
Power rating (RMS/Peak)	410W / 1600W
Frequency range	50 - 19kHz (10dB)
Nominal impedance	8 ohm
Transducer type	15" MF (2.5in VC) EU transducer 1" HF driver (1.73in VC) EU transducer
Dispersion	CD horn, 90°x60° and 60°x90° user-rotatable
Crossover frequency	2000Hz
SPL (1W/1kHz)	129dB @ 1m
Sensitivity	96dB
Connector	2x NL4 parallel-connected

### Mechanical

Enclosure	15mm birch plywood, rugged polyurea coating
Grille	Custom perforated metal grilles w/ acoustic foam
Color	Black or white textured
Hardware	4 rubber feet Side handles, 4x M8 inserts + 2x M10 inserts Prepared to fit a "U" bracket
Dimensions	730x485x360mm   28.74x19.09x14.17in
Weight	25Kg   55.16lb

