

WX15PS

Presentation:

WX15PS is an ALL-weather installation speaker designed for outdoor use in applications such as stadiums, transport hubs, parks, any outdoor venue that achieves excellent results and excellent acoustic performance.

Very versatile, this sound projector operates in both high impedance 100V line and 8ohm low impedance applications being adapted to different types of installation. It features a line of screw-terminals for power tapping, covered by a dustproof, waterproof rear panel cover.

The WX15PS incorporates a COAX loudspeaker of 15" (3in VC) LF woofer + 1" (3in VC) HF driver on a horn-loaded concept, that combined can offer a clear sound for mid-long throw applications.

Made of UV resistant polypropylene, its housing is IP56 rated, using stainless steel screws for the grill and wall mount bracket.

With a powder coated aluminum grill protected with 4 layers of foam and cloth, the WX15PS is supplied with a wall mount bracket for a quick and easy installation.

Standard color is black and other colors may be available on request.

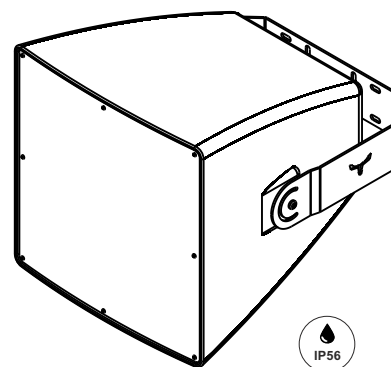

Features:

- All-weather sound projector
- Horn-loaded design
- 15" LF (3in VC) + 1.4" HF (3in VC) combination (coax)
- Suitable for 8ohm/100V imp. installations
- Screw-terminals with cover
- Wall mount bracket included
- UV resistant polypropylene housing - IP56
- Powder coated AL grill with foam + cloth
- Available in black, other colors on request

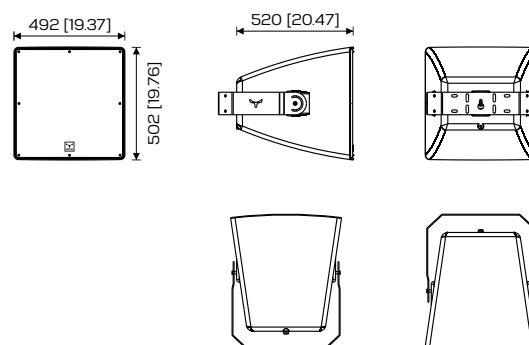

Technical specifications:

Acoustical

Type	2-way, COAX sound projector Horn-loaded design
Low impedance power	400W @ 8ohm
Hi impedance power	75W / 150W / 300W (power tapping)
Transducer type	15" (3in VC) LF + 1.4" (3in VC) HF transducer
Impedance	80hm
Frequency range	45Hz - 20kHz (-10dB)
Dispersion (HxV)	60°x 40°
Crossover frequency	1.5kHz passive
Max. SPL	135dB

Mechanical

Connectors	Screw-terminals
Colour	Black (standard color), others on request
Housing	UV resistant ABS (polypropylene)
Grille	Powder coated AL grill, foam + cloth
IP rating	IP56
Mounting accessories	Wall mount bracket included
Dimensions	492x502x520mm / 19.37x19.76x20.47in
Weight	31Kg / 68.34lb

